



<https://www.pafa.org>

Pennsylvania
Academy of
the Fine Arts

Guide to Student Life at PAFA & Living in Philly

First-Year
Students!



GET TO KNOW MORE ABOUT YOUR HOME AT PAFA

Contact PAFA:

admissions@pafa.edu

PAFA FIRST-YEAR GUIDE

WHAT'S NEAR YOU?

Grocery Stores & Markets... 1-2

Local Hardware & Craft Stores
etc. ...3-4

Arts & Entertainment...5

Gyms & Fitness Clubs... 4



OFF-CAMPUS HOUSING RESOURCES

Local Apartment Rental ... 7-8

Off-Campus Studio Spaces...9

Furniture & Storage Supply
Stores...10

EXTRA TIPS & RESOURCES

Neighborhoods of
Philadelphia... 11-12

PAFA Housing & Damage
Fees... 13-15

Bike Locking and Storage... 16



**WHAT'S
NEAR YOU?**

GROCERY STORES & MARKETS

Grocery Stores/ Markets:

Asia Fresh Food Market

A simple supermarket specializing in imported products from Asia, plus produce, meat & prepared foods.

**143 N 11th St Philadelphia 19107
(215) 928-9888**

Iovine Brothers Produce - Reading Terminal Market

Busy, health-conscious store stocking a large selection of fruits & vegetables, plus juices & nuts.

**1136 Arch St Philadelphia 19107
(215) 928-4366**

Fair Food Farmstand

A Market for fresh produce, meat, dairy, cheese & eggs sourced from 90+ local sustainable farmers.

**51 N 12th St Philadelphia 19107
(215) 386-5211 ext. 120**

Trader Joe's

Grocery chain with a variety of signature items, plus produce, dairy & more.

**2121 Market St Philadelphia 19103
(215) 569-9282**

Reading Terminal

Indoor farmer's market providing grocery, dining & shopping needs.

**1136 Arch St, Philadelphia, PA 19107
(215) 922-2317**

Rittenhouse Market

Small mainstay offering groceries, gourmet foods, produce, seafood, a deli & delivery service.

**1733 Spruce St Philadelphia 19103
(215) 985-5930**

Whole Foods Market

Eco-minded chain with natural & organic grocery items, housewares & other products.

**929 South St Philadelphia 19147
(215) 733-9788**

Old City Food Market

No-frills corner store stocking basic groceries features a deli that makes hoagies & sandwiches.

**202 Market St Philadelphia 19106
(215) 238-9484**

Acme Markets

Standard big -box supermarket

**309 S 5th St Philadelphia
(215) 413-9715**

Target

Standard department/supermarket store

**1 Mifflin St Philadelphia, PA 19148
(215) 463-7311**

Grocery Stores That Deliver:

Instacart

Groceries delivered in 1 hour

Shoprite

Shop from home

GROCERY STORES & MARKETS

Bulk Goods:

BJ's in South Philly

Member-only big box store

**2300 Oregon Ave. Philadelphia, PA
19145**

Philadelphia Sam's Club

Member-only big box store

**1000 Franklin Mills Cir. Philadelphia,
PA 19154
(215) 632-2299**

Convenience Stores:

7-Eleven

Convenience chain offering grab-and-go bites & beverages, plus assorted newsstand items.

**150 N Broad St Philadelphia 19102
(215) 575-0827**

Wawa

24-hour convenience store

**1707 Arch St Philadelphia 19103
(215) 977-9558**

CVS

Convenience drug and food chain

**1424 Chestnut Street Philadelphia, PA
19102
215-963-9316**

Philly has a ton of accessible grocery stores and plenty of places to eat out, if you're not much of an at-home chef.

LOCAL HARDWARE & CRAFT STORES

Hardware Stores:

10th Street Hardware
257 S. 10th Street 215-922-0720

Rittenhouse Hardware
2001 Pine Street #2 215-735-6311

Fairmount Hardware
2011 Fairmount Ave 215-765-4500

Cohen & Co. Hardware and Home
Goods
615 E Passyunk Ave 215-922-3493

Monarch Hardware Company
4502 Walnut Street 215-387-4199

1540 Hardware
1540 E Passyunk Ave 215-336-1515

The Home Depot Locations:

1651 S Christopher Columbus Blvd.
215-218-0600

2539 Castor Ave
215-744-1128

2200 W. Oregon Ave
215-551-1753

Lowe's Home Improvement:

2106 S. Christopher Columbus Blvd.
215-982-5391

3800 Aramingo Ave
215-904-9951

Other Lumber and Wood Sources:

Tague Lumber, Inc.
560 High Street 215-848-2500

Torres Lumber Co. Inc.
4365 Rising Sun Ave 215-324-1360

Scrap Yards:

Philadelphia Scrap Metal
2069 E. Silver Street 215-739-1175

Nicholas Scrap Metal Inc.
3812 Old York Rd. 215-225-2121

Arts and Crafts Stores

The Resource Exchange (2nd Hand
Store for art supplies, lumber, craft
items, fabric, etc.)
1701 N. 2nd Street
267-997-0060

Artist and Craftsman
307 Market Street
267-861-6008

Blick Art Materials
1330 Chestnut Street
215-545-3214

Rittenhouse Needlepoint
1737 Chestnut Street #201
215-563-4566

Plaza Artist Materials and Picture
Framing
3200 Chestnut Street
215-823-6893

LOCAL HARDWARE & CRAFT STORES

Continued...

Jack B. Fabrics
748 S. 4th Street
215-925-2991

B. Wilk Fabrics
801 S. 4th Street
215-627-1146

Jomar Textiles Inc.
22 Jackson Street
215-339-5802

These are not all the hardware and craft stores, lumber and scrap yards, and art supply store in Philly. However they cover the general region and are rated the highest.

ARTS & ENTERTAINMENT

Art Museums:

Philadelphia Museum of Art
Barnes Foundation
Rodin Museum
The Mutter Museum
Philadelphia Magic Gardens
Museum of Illusions
The Franklin Institute of Science
Edgar Allen Poe House
etc.

Art Collectives:

Crane Arts Studio
The Clay Studio
Second Street Press
Bok Building
Space 1026
etc.

Music / Performing Arts Venues:

Kimmel Center
The Met
World Café Live
The Mann Center
The Fillmore
Underground Arts
Union Transfer
Theater of the Living Arts
Wells Fargo Center
Walnut Street Theater
The Academy of music
Philadelphia Theater Company
Wilma Theater
Philadelphia Ballet
Fringe Arts
etc.

**These are not all the arts and entertainment spots in Philly.
However, these are the most well-known.**

WHERE CAN YOU EXERCISE NEAR PAFA?

Fusion Gym

2801 Grant Ave

856-300-2432

Philadelphia Sports Club

1735 Market Street

215-564-5353

Retro Fitness

1500 Spring Garden Street

267-519-3799

Sweat Fitness

1 South Broad Street

215-351-0100

CrossFit Center City

1229 Chestnut Street

267-909-8210

RowZone Indoor Rowing and Fitness Center

4401 Main St

215-798-0175

Hot Yoga Philadelphia (Discount for PAFA

students!)

1520 Sansom Street

215-977-9642

Maha Yoga

1700 Sansom Street

215-864-0770

Philadelphia Sports Clubs

220 S 5th St

215-592-8900

These are just a few of the gyms, fitness centers, and exercise communities to participate in recreational activities. Be sure when contacting the facility that you ask about student discounts!

OFF- CAMPUS HOUSING

LOCAL APARTMENT RENTAL

**Philadelphia Apartment
Management Companies
(Use Ctrl + click to access links!)**

**PMC Property Group:
(215) 241-0200**

**1900 Arch
.5 miles from PAFA
Rent ranges from \$1680-\$6225**

**Embassy Apartments (2100 Walnut
Street) 1 mile from PAFA
Rent starts at \$1345**

**2311 Spruce Street
1.3 miles from PAFA
Rent starts at \$1545**

**2040 Market
.8 miles from PAFA
Rent ranges from \$1775-\$3295**

**Liberty View Apartments (2031
South Street)
1.3 miles from PAFA
Rent ranges from \$1295-\$1645**

**Michael Singer Real Estate:
(215) 925-8683**

**The Chatham (135 S. 20th Street)
.9 miles to PAFA
Rent ranges from \$1375-\$1800**

**Signature Investment Realty:
(215) 222-2220**

**Beacon Hill Apartments (1330 Pine
Street)
.8 miles from PAFA
Rent ranges from \$895-\$975**

**2213 Walnut Street
1.2 miles to PAFA
Rent starting at \$835**

**Lippincott Court
1.3 miles to PAFA
Rent starting at \$1000**

**Cypress Court (304 S. 23rd Street)
1.3 miles from PAFA
Rent starting at \$695**

**2129 Pine Street
1.3 miles to PAFA
Rent starting at \$635**

Other Suggested Realty Groups:

**Property Management Group
(215) 545-7007
311 S. 13th Street**

**William Penn Realty Group
(215) 636-0300
19 S. 21st Street**

**Volpe Real Estate Inc.
(215) 545-5414
701 S. 20th Street**

LOCAL APARTMENT RENTAL

Helpful Websites and Apps

Trulia

Access to apartment listings
App available for Apple and Android devices

Zillow

Access to apartment listings
App available for Apple and Android devices

Craigslist

Frequently updated website including apartments for rent, sublets, shares, and roommate searches

University of Pennsylvania Off-Campus Living

Listings include apartments for rent and roommate searches

Broad Street Classifieds

Access to apartment listings

Philadelphia Weekly

Online, free paper including a classified section,
listing apartments for rent

4 Walls in Philly

Access to apartment listings, with searches available by neighborhood and student housing options

STUDIO SPACES IN PHILADELPHIA

The LOOM Philly

3245 Amber Street
215-525-1734

Crane Artist Studios

1400 N. American Street
215-232-3203

Viking Mill

2026 E. Hagert Street
267-226-5969

47arts

47 High Street
215-842-2028

Global Dye Works

4500 Worth Street 215-288-4554

BOK Building

1901 S. 9th Street
hello@buildingbok.com

Studios @ 2202 Alter Street

2202 Alter Street
215-893-8812

The PaperMill Community of Artists

2825 Ormes Street
215-687-8391

Stenton Guild Arts Building

4732 Stenton Ave
215-843-5640

Herman Street Studios

20 E. Herman Street
215-669-2993

The studios listed above are not the only spaces available in Philly. Craigslist is also a great resource to find spaces to rent or to find other artists looking to share a spot!

FURNITURE & SUPPLIES IN PHILADELPHIA

New Furniture and Storage supplies:

Ikea

2206 S Christopher Columbus Blvd
Philadelphia, PA 19148

West Elm

1330 Chestnut St. Philadelphia, PA
19107

Target

1900 chestnut St. Philadelphia, PA
19103

OR

1128 Chestnut St. Philadelphia, PA
19107

Walmart

1675 S. Christopher Columbus Blvd
Philadelphia, PA 19148

Macy's

1300 Market St. Philadelphia, PA
19107

Lowe's

2106 S. Christopher Columbus Blvd
Philadelphia, PA 19148

Home Depot 1651 S. Christopher
Columbus Blvd Philadelphia, PA
19148

Second Hand furniture and storage supplies:

Habitat for Humanity ReStore

2318 Washington Ave Philadelphia,
PA 19146

Resource Exchange

1701 N 2nd St. Philadelphia, PA
19122

Uhuru

832 N Broad St. Philadelphia, PA
19130

Philly Aids Thrift

710 S. 5th St. Philadelphia, PA
19147

Bargain Thrift Center

4530 Germantown Ave
Philadelphia, PA 19144

Jinxed Fishtown

1331 Frankford Ave Philadelphia,
PA 19125
(215) 800-1369

**EXTRA RE-
SOURCES**

NEIGHBORHOODS OF PHILADELPHIA

Logan Square, Spring Garden & Fairmount: These areas are located along Benjamin Franklin Parkway with the Philadelphia Museum of Art, the Barnes Foundation and the Rodin Museum nearby. Those living here enjoy many cultural and recreational activities close to home with residential neighborhoods, restaurants, bars, and café's. Fountains, flowers and flags adorn the tree-lined Parkway.

Housing options: Row houses line most of the streets of Fairmount, but you will also find several high-rise apartment complexes. Housing prices are comparable to Center City, but parking is tricky.

Transportation: Because of its proximity to the Benjamin Franklin Parkway, which runs directly toward City Hall, buses are an extremely useful form of transportation in this area. Also, because the Art Museum Area sits adjacent to Fairmount Park, many of the locals travel by bicycle.

Rittenhouse: The neighborhood occupies the southwest corner of Center City. Rittenhouse square, itself, is a prestigious park and destination with dozens restaurants and shops within walking distance.

Housing Options: The area is home to a diverse group of people including single professionals, families with children and an increasing number of retirees who are rediscovering the joys of city life.

Transportation: The area is in close proximity to all of Center City, but parking is an expensive challenge. Bicyclists abound, and taxis are ready to take you anywhere you want to go.

Chinatown & Callowhill: This area of Philadelphia is one of the fastest-growing areas in Center City, a prospering community nestled between the Pennsylvania Convention Center and just north of the Vine Street Expressway. It is richly cultural, and a popular residence for medical students studying at nearby Jefferson and Hahnemann Hospitals. An exceptional dining scene highlights Chinatown, with cheap eats, ideal for students on a budget. The Vox Populi gallery complex is a great place to see art on the weekends!

Housing options: With the recent expansion of the Pennsylvania Convention Center, new hotels and condominiums continue to sprout. Apartments in this area distinctly contrast the historic brownstones that typify Center City living.

Transportation: Chinatown & Callowhill are only a few blocks from PAFA. Students here will have no trouble walking to school, regardless of the weather.

Market East: Market East serves as Philadelphia's shopping and entertainment gateway. Nestled in between Old City and Rittenhouse Square, this exciting neighborhood is home to the City Hall, Macy's department store in the historical Wanamaker Building and Reading Terminal Market. Numerous restaurants, clubs and theaters are within walking distance.

Housing options: Though Market East is known for the shopping and entertainment, some studio apartments, one-, two- and three- bedroom apartments are available in many apartment buildings and lofts. Parking is a big challenge here; on- street spaces are rarely available.

Transportation: Take the bus, subway or a taxi, and nearly everything in Center City is accessible on foot.

NEIGHBORHOODS OF PHILADELPHIA

Washington Square West: Washington Square West is a colorful part of Philadelphia. You'll find townhomes and brownstones throughout this neighborhood, as well as performing arts venues on the Avenue of the Arts.

Housing Options: Similar to Rittenhouse Square, many small apartments are found in Washington Square West. They often carry premium prices, but small or shared spaces remain within a student's budget.

Transportation: This area is walking-distance from everything in Center City.

Old City & Society Hill: Old City is the birthplace of Philadelphia. It is home to the Liberty Bell, Independence Mall, and dozens of historical attractions. Numerous restaurants, clubs and theaters are within walking distance. Old City also houses many of the city's Art Galleries.

Housing options: Housing in Old City is at a premium, and costs can be substantial. Parking is a challenge here; on-street spaces are rarely available.

Transportation: Take the bus, subway or a taxi, and nearly everything in Center City is accessible on foot.

Bella Vista & East Passyunk (South Philadelphia): The communities in South Philly have been described as the city's most colorful and ethnically diverse neighborhoods. South Philadelphia is also home to several of Philly's famous cheesesteak vendors, and also the Italian and Mexican Markets: full of grocers, cafes, restaurants, bakeries, and cheese and butcher shops.

Housing options: Ground-level shops and traditional row homes cover the area. The neighborhood is heavily residential.

Transportation: The neighborhood is near the Broad Street Subway Line, which conveniently transports students toward downtown. By bike, you can easily get to Center City in 15-20 minutes.

University City: University City encompasses the campuses of the University of Pennsylvania and Drexel University. The area is heavily student oriented, and located across the Schuylkill River from Center City.

Housing Options: The area is filled with off-campus student housing, including many apartment rentals.

Transportation: Bus lines run along Market, Chestnut, and Walnut streets and provide easy access to Center City. The Market-Frankford Subway line and several trolley lines also travel through University City. Many students own a bicycle in this area.

Northern Liberties & Fishtown: In recent years, the Northern Liberties & Fishtown areas of Philadelphia have experienced a revival. Due to recent improvement and revitalization projects, the area has become a center for local artists and musicians.

Housing options: Row homes are the primary residential option. Apartment costs now regularly parallel Center City prices.

Transportation: Bicycles and public transportation options. The Market-Frankford Subway Line has several stops in Northern Liberties and Fishtown. PAFA is about 20 minute commute.

PAFA HOUSING DAMAGE FEES

All listed charge types reflect a "per person" charge. Split charges are not applicable.

Charge Type	Charge Amount
Adhesive Removal	\$50.00 per sticker
Bed assembly/disassembly	\$65.00 per bed
Cinder Block Removal	\$10.00 per bed
Damage not defined (vandalism)	\$5.00 minimum
Dirty Room at Check-Out	\$70.00 per person
Door Damage	\$150.00 minimum
Failure to remove belongings from room	\$100.00 minimum
Floor damage	\$50.00 minimum
Furniture damage	\$50.00 - \$300.00
Furniture rearrangement	\$50.00 - \$200.00
Graffiti Removal	\$25.00 minimum
Holes	\$50.00 - \$3,000.00
Improper Use of Lounge Furniture	\$50.00
Kitchen Cabinet/Drawer Damage	\$50 Minimum

PAFA HOUSING DAMAGE FEES

All listed charge types reflect a "per person" charge. Split charges are not applicable.

Charge Type	Charge Amount
Late Check-Out/Failure to Move-Out	\$50-\$400.00
Light bulbs/lenses damaged or missing	\$85.00 each
Lock Change - Stiles 1 bedroom apartment	\$150.00
Lock Change - Stiles 2 or 3 bedroom apartment	\$225.00
Lock Out Policy	\$25.00
Malicious Act of Vandalism	\$500.00
Mattress Replacement	\$135.00
Mirror Replacement	\$75.00
Move-in Cart Not Returned/Damaged	\$350.00
Paint Removal	\$50.00 minimum
Personal Waste Materials Removal	\$25.00 minimum
Refinish Desktop	\$185.00
Replace Door Closer (Fire Safety Equipment)	\$250.00
Replace Exit sign	\$350.00

PAFA HOUSING DAMAGE FEES

All listed charge types reflect a "per person" charge. Split charges are not applicable.

Charge Type	Charge Amount
Replace paper towel dispenser	\$100.00
Replace Screens	\$75.00
Replacement of Couch	\$895.00
Replacement of Student Desk Chair	\$135.00
Replacement of Table	\$375.00
Tampering with Fire Safety Equipment	\$350.00 per piece
HVAC Unit/ Thermostat damaged/ removed	\$75.00 minimum
Towel Bar replacement	\$50.00
Wall damage - varies in size, includes corridors	\$50.00 - \$500.00
Window Boarding Charge	\$150.00 - \$800.00
Window Limiters	\$10.00
Window replacement (varies in size)	\$150.00 - \$3000.00
Window treatment damage	\$50.00 - \$150.00

BIKE LOCKING & STORAGE

U-LOCK & CABLE LOCK



CHAIN & CABLE LOCK



CABLE LOCK ONLY



FRAME ONLY



U-LOCK

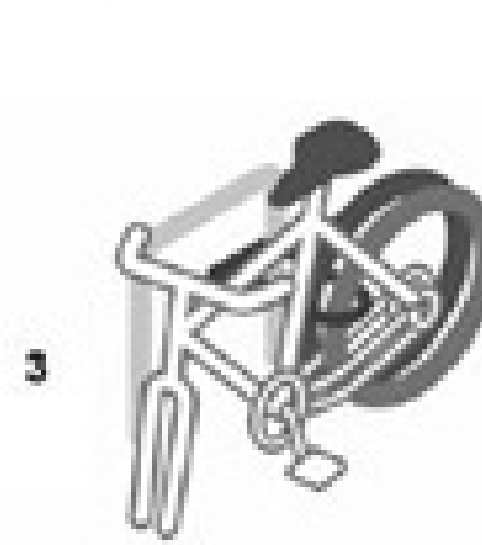
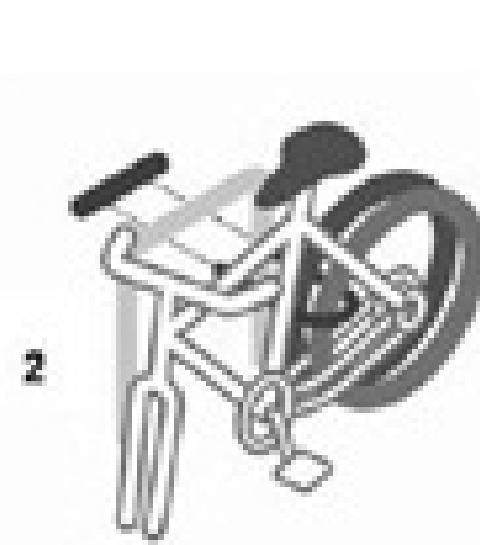
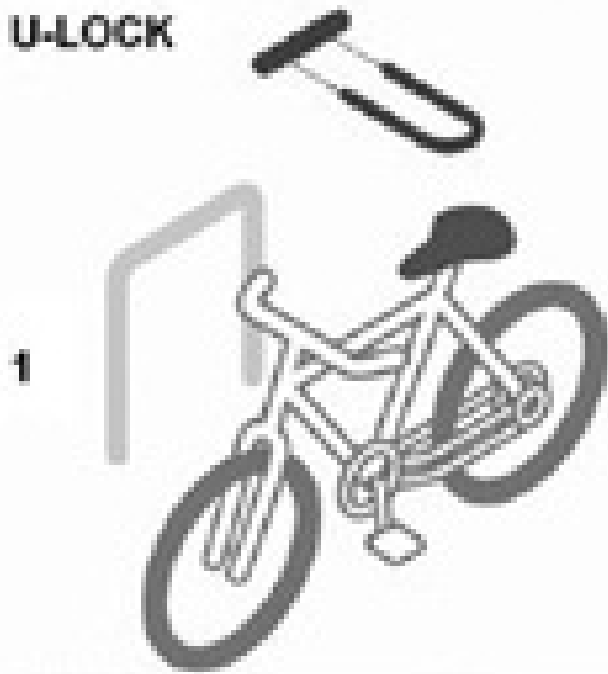

FRONT WHEEL ONLY



There are convenient bike racks outside of PAFA. Make sure to bring your lock and lock your bike correctly. PAFA is not responsible for lost or stolen bikes!

Pennsylvania Academy of the Fine Arts: First-Year Housing Guide

We hope you found this guide helpful. For more resources and feedback, feel free to reach out to Office of Students Services.